



Industrial Conveyor Specialists

MODEL 104
SLIDER BED CONVEYOR



The Model 104 Slider Bed Belt is designed with the systems approach in mind. The square head and tail end terminals and the standard 4" deep formed frame allow you the flexibility to combine this unit with other Titan models to assure a continuous flow of material. This is our most popular slider bed conveyor and is suitable for most applications requiring a basic belt conveyor to move material from point A to point B. Screw type take-ups and 4" diameter crown face pulleys are some of the standard design features. Modular design allows you the flexibility to add additional sections if required.

As with all Titan Conveyors, there is an endless list of options to customize your conveyor.

MODEL 104 SLIDER BED CONVEYORS SPECIFICATIONS		
	STANDARD	OPTIONS
Belt Widths	4" thru 48"	Specify
Lengths	2' to 10'	3' to 40'
Belt Type	PVC 120 Black	Rough top, V-guide on bottom, Food Grade or belt to suit application
Drive	1/2 Hp 230/460/3/60	3/4, 1, 1-1/2, 2 HP 115/230/60, TEFC, severe duty, inverter duty, brake motor
Drive Pulley	4" dia. crowned, rubber lagged	Machined & balanced pulleys for high speed
Frame	4" deep formed 12 ga.	
OPTIONAL		
H.P., drive location, speed, fixed or variable speed, belt type, siderails, center drive & take-upm supports, casters, side take-up, galvanized, stainless, transfer roller, special paint, belt scraper, food grade, Many other options available, consult factory representative		

MODEL 104 SLIDER BED BELT

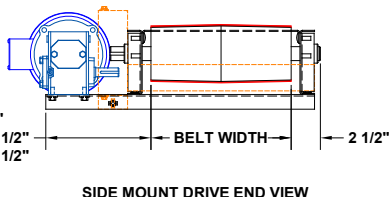
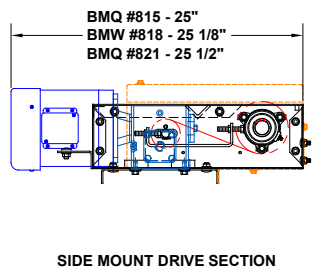
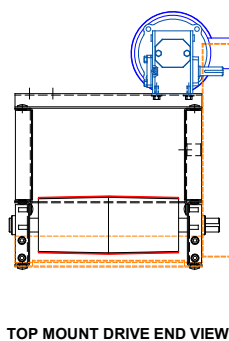
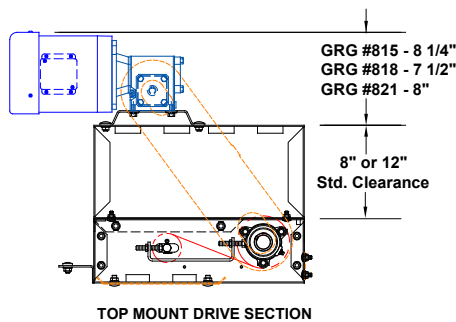
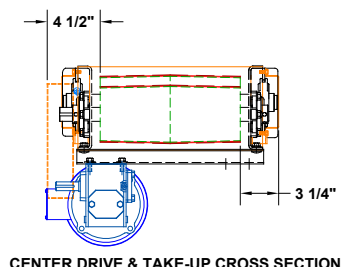
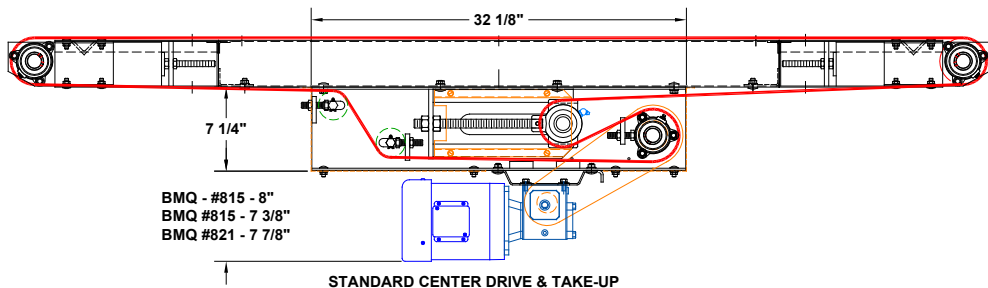
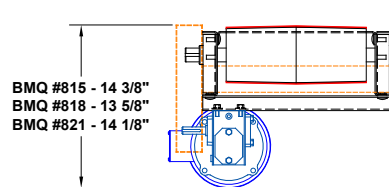
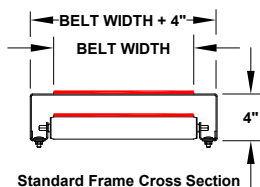
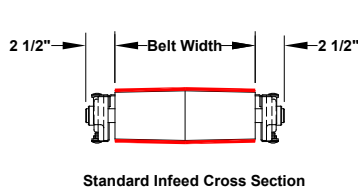
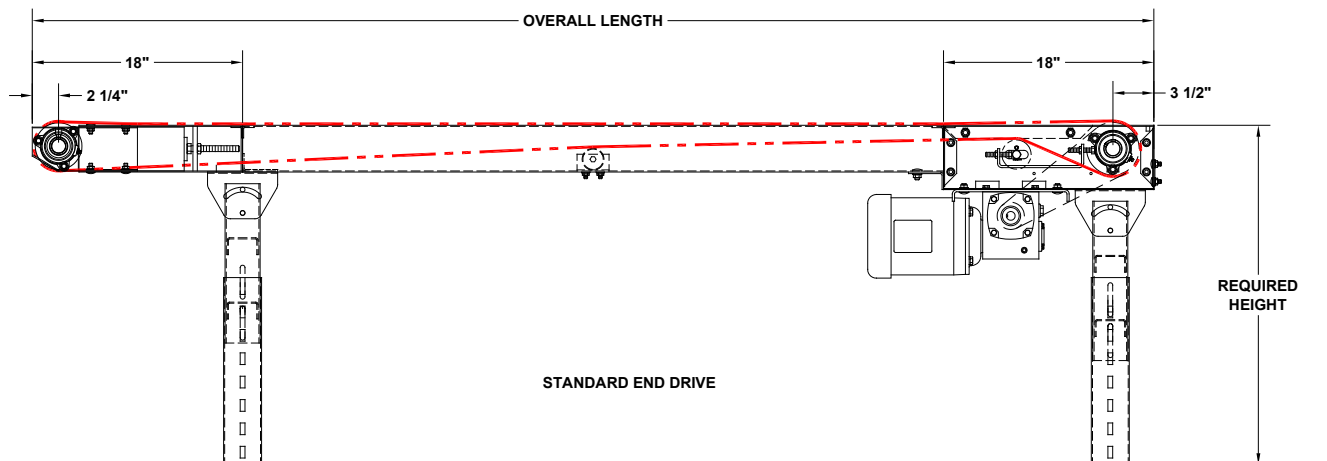

Website: www.titanconveyors.com • Email: sales@titanconveyors.com
 735 Industrial Loop Road • New London, WI 54961-9612
 920-982-6600 • Fax: 920-982-7750 • Toll Free: 800-558-3616