

MODEL 200 POWERED TURNTABLE CONVEYOR

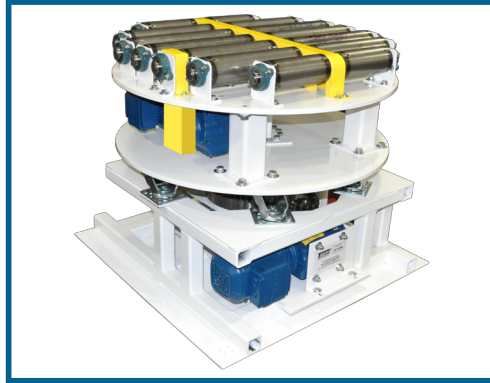

When your plant layout requires a directional change in the smallest possible space, you should consider using a Titan Powered Turntable. The turntable can be used for product sortation, accumulation as well as directional changes. The Titan Turntable is available in sizes ranging from 2' diameter to 10' diameter. The standard table top is 7 gauge construction with angle iron supports. The top is driven by either chain and sprockets or a contact wheel. The unit is furnished with expanded metal guards on all four sides. Roller supports supplied as optional equipment. The unit can be supplied with chain and sprocket drive, air operated for 90° rotation or no drive for manual indexing. Tops can be fitted with gravity roller or chain driven live roller conveyor to suit your application

MODEL 200 TURNTABLE		
	Standard	Options
Diameters	24", 36", 48", 60", 72", 84", 96"	Other diameters available
Drive Location	Bottom mount	
Deck	7 ga. Carbon Steel	Others available
Drive	1/2 H.P. 230/460/3/60	3/4, 1, washdown, severe duty, inverter duty, brake motor
Speed	Various	fixed speeds, variable speed
Deck Rollers	2-5/8" dia. x 7 ga with 11/16" hex shaft	
Frame	Designed per application	
OPTIONAL		
H.P., speed, fixed or variable speed, controls, cam followers, detents, galvanized, stainless, siderails, supports, transfer roller, e-stop with pullcord, casters, special paint		

NOTE: Specifications subject to change without notice

POWERED TURNTABLE

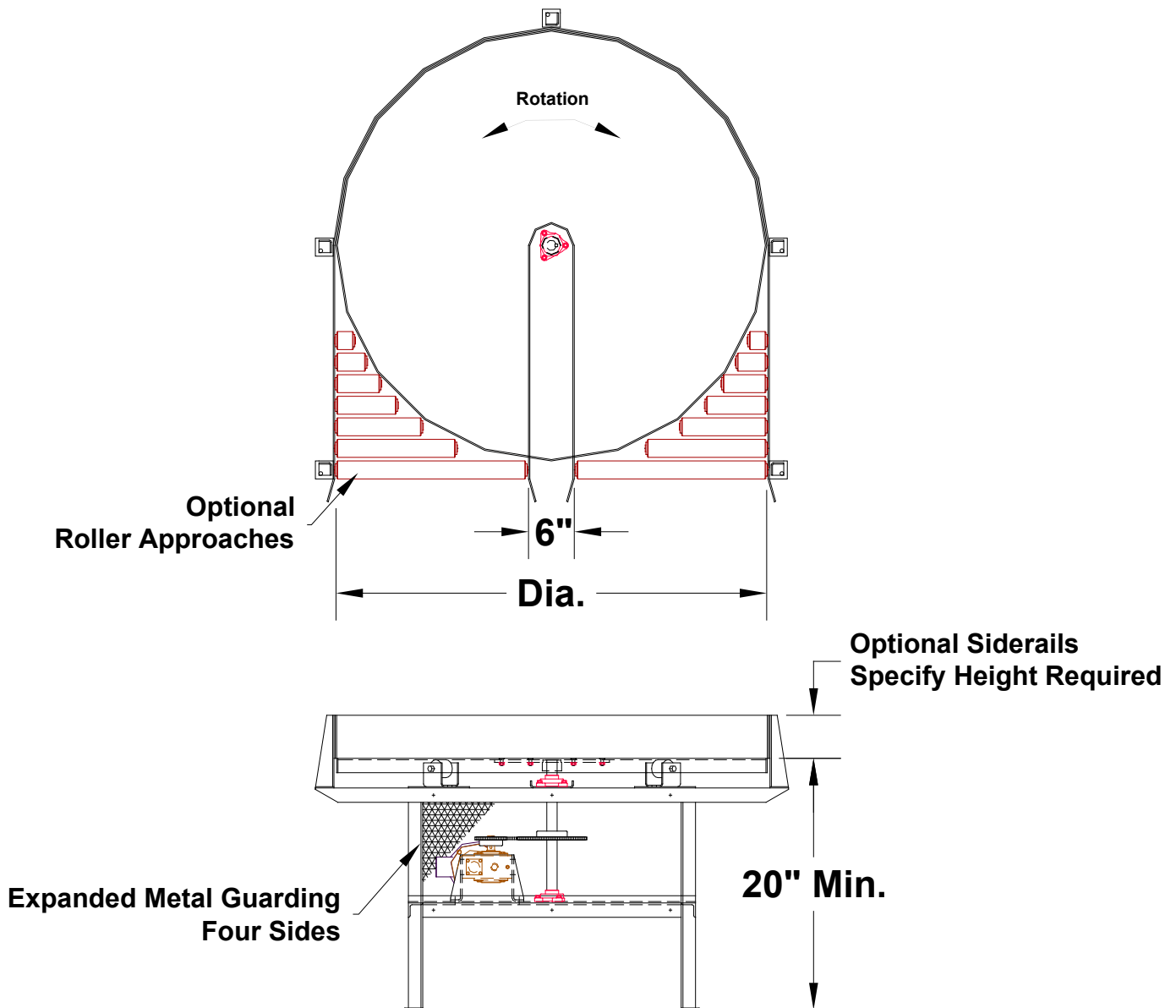

TITANTM
CONVEYORS

735 Industrial Loop Road • New London, WI 54961-9612
(920-982-6600 • Fax (920-982-7750 * Toll Free 800-558-3616
Website: www.titanconveyors.com Email: sales@titanconveyors.com