

MODEL 610

HINGED STEEL BELT CONVEYOR

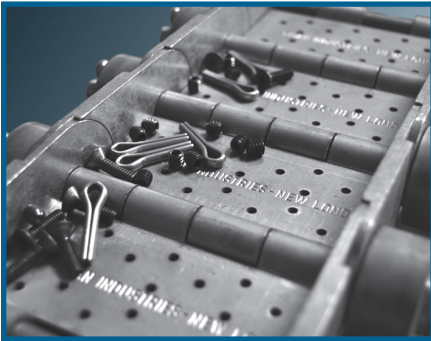

The Titan Model 610 Chip Conveyor fits the needs of today's machine tool environment. Starting with the low profile 12 gauge frame (6-11/16" deep) this unit is designed for rugged chip handling applications. **Standard features include flared infeed siderails, liquid tight bottom pan, 2" high vertical siderails with bolt on top cover and chip suppressor, bushed sprockets on the infeed and low profile side mount drive.** Belt widths are available from 6" to 24" with plain, perforated or pimpled belt styles available. The 10 F.P.M. belt speed allows for adequate coolant drainage. The Model 610 features the exclusive Titan radial sidewing that virtually eliminates any gap between the sidewings and aprons, thus reducing jamming problems. The unit shown above has optional drain holes on the infeed and an optional right hand drive.



2-1/2" RADIAL SIDEWINGS

Exclusive Titan radial sidewing prevents jamming, even with the smallest parts

MODEL 610 2-1/2" PITCH HINGED STEEL BELT CONVEYOR		
	STANDARD	OPTIONS
Belt Widths	6", 8", 12", 18", 24"	4", 10", 14", 16"
Belt	2-1/2" pitch plain hinged steel with 1" radial sidewings	Perforated, pimpled, perforated & pimpled, impact plates
Drive	1/2 HP 230/460/3/60	3/4, 1 HP, Severe duty, brake motor
Speed	Per Application: 5-30 Typical	Specify
Drive Location	Side mount	Top mount end
Curves	30°, 45°, 60°	Special Curves
OPTIONAL		
Motors, controls, wiper cleat, 6" bulb infeed, welded barrels, paint color, bolt on bottom pan, liquid tight bottom pan, bolt on top cover, drain holes, drain plug, infeed siderails, casters, coolant tanks, pumps, zero speed switches, rotary belt brush		

NOTE: Specifications subject to change without notice

MODEL 610

HINGED STEEL BELT CONVEYOR

Model 610 - A variety of types to fit you needs

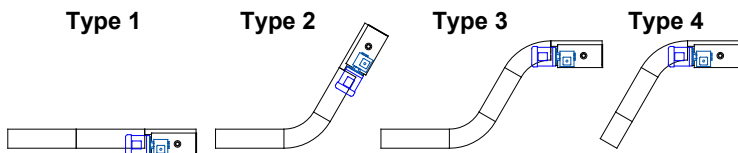

Special Model 610 with hopper & step plate

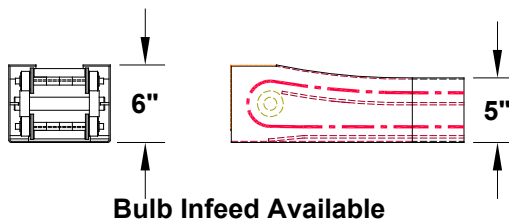
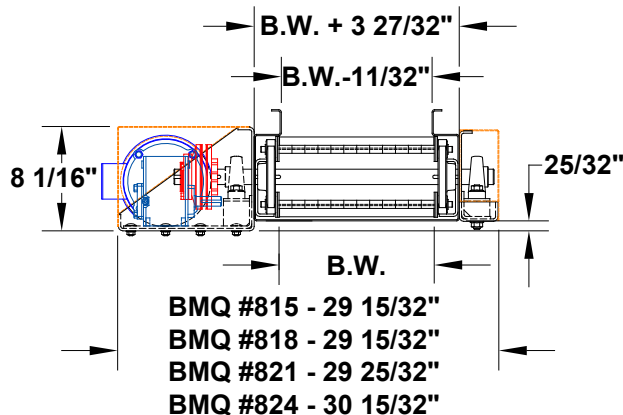
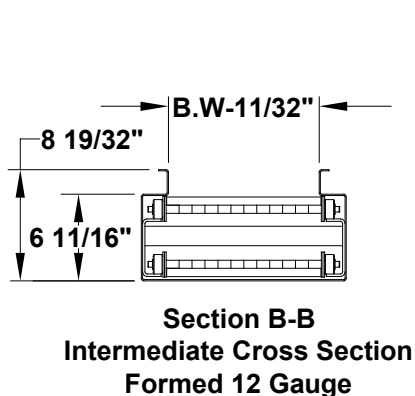
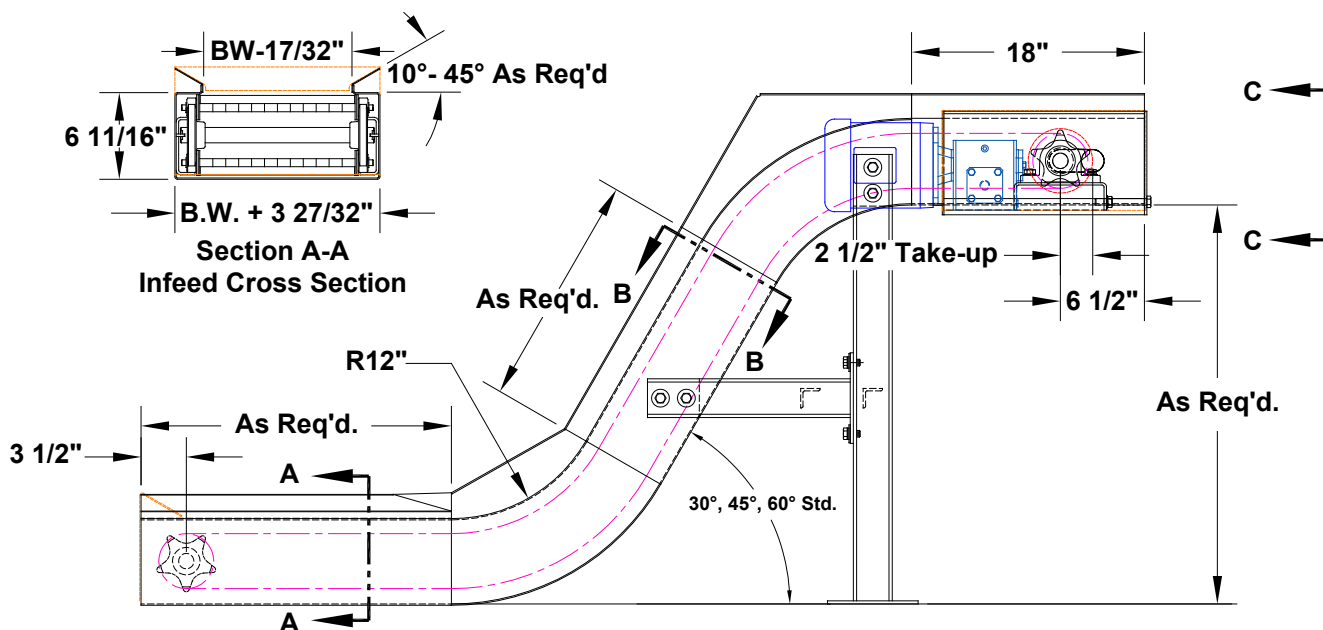

Bulletin 0519_610GH

735 Industrial Loop Road • New London, WI 54961-9612
 920-982-6600 • Fax 920-982-7750 • Toll Free 800-558-3616
 Website: www.titanconveyors.com • Email: sales@titanconveyors.com

