



# Replacement Parts RFQ for Model 661 - Chain Edge Conveyor

**Note:** Chrome Browser will not email - Download form and attach to an email to: [sales@titanconveyors.com](mailto:sales@titanconveyors.com)

Company

Phone

Contact

Conveyor  
Serial Number

E-mail

To Request a Quote for Spare Parts - Fill in the Information below & Quantity of each Part & Click on the Email Button

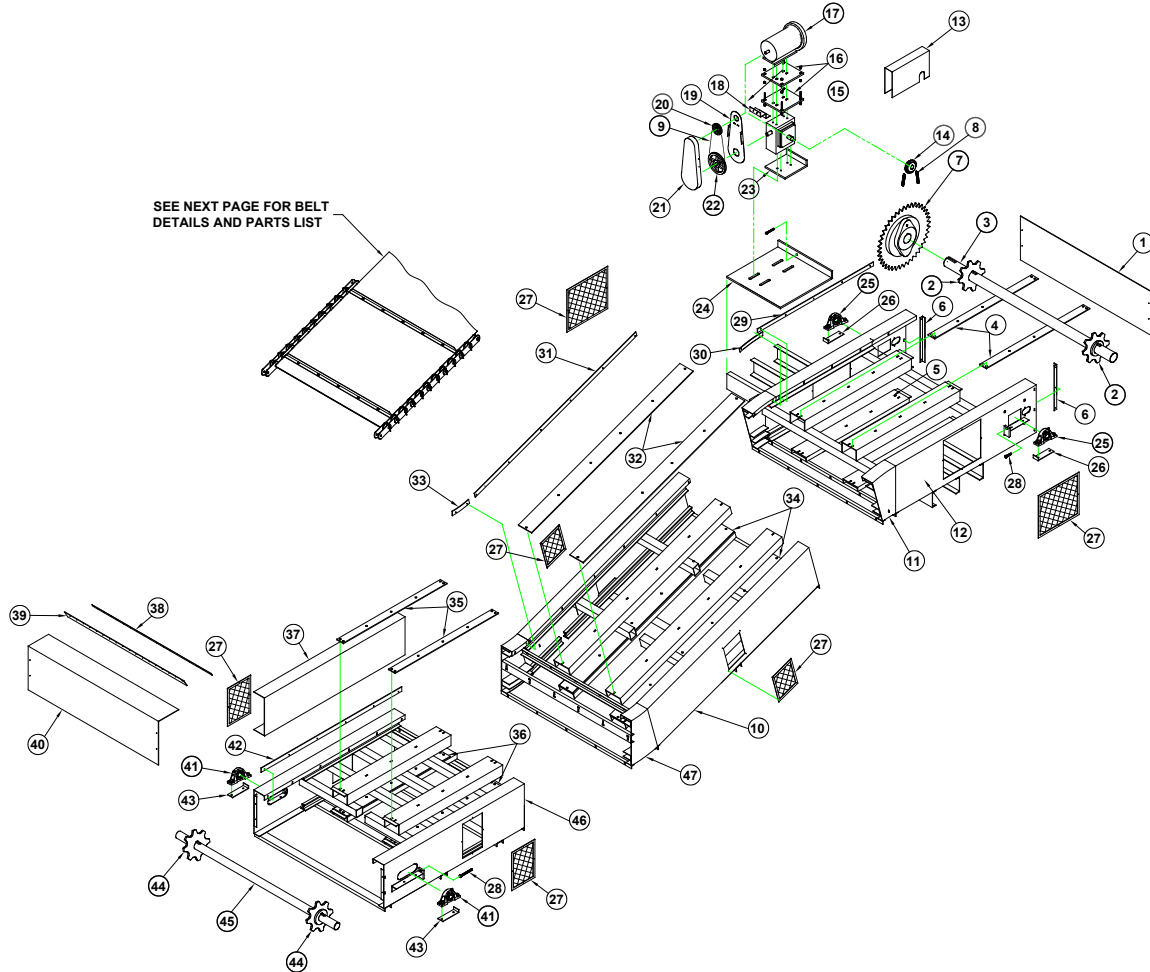

• Recommended spare parts to be stocked at your location

Part

Number - Description - Qty.

- 2. • DRIVE BELT SPROCKET
- 3. • DRIVE SHAFT
- 7. • SHEAR PIN ASSEMBLY
- 8. • ROLLER CHAIN
- 9. • V-BELT
- 14. • DRIVE SPROCKET
- 15. • REDUCER
- 17. • MOTOR
- 20. • DRIVE SHEAVE
- 22. • DRIVEN SHEAVE
- 25. • DRIVE PILLOW BLOCK BEARING
- 41. • INFEEED PILLOW BLOCK BEARING
- 44. • INFEEED BELT SPROCKET
- 45. • INFEEED SHAFT

Other Parts

- 1. DRIVE END CAP
- 4. DRIVE TOP WEARSTRIP
- 5. DRIVE RETURN WEARSTRIP
- 6. END CAP MOUNTING BRACKET
- 10. INCLINE FRAME
- 11. UPPER CURVE
- 12. DRIVE FRAME
- 13. SPROCKET GUARD
- 16. MOTOR BASE
- 18. GUARD BACK BRACKET
- 19. SHEAVE GUARD BACK
- 21. SHEAVE GUARD FRONT
- 23. DRIVE PUSHER PLATE
- 24. DRIVE MOUNTING BASE
- 26. BEARING PUSHER PLATE
- 27. INSPECTION COVER
- 28. PUSHER BOLT
- 29. DRIVE SKIRTING
- 30. UPPER CURVE SKIRTING
- 31. INCLINE SKIRTING
- 32. UPPER INCLINE WEARSTRIP
- 33. LOWER CURVE SKIRTING
- 34. INCLINE RETURN WEARSTRIP
- 35. UPPER INFEEED WEARSTRIP
- 36. INFEEED RETURN WEARSTRIP
- 37. SIDERAIL (OPTIONAL)
- 38. FLAPPER HOLD DOWN
- 39. FLAPPER
- 40. INFEEED END CAP
- 42. INFEEED SKIRTING
- 43. INFEEED BEARING PUSHER PLATE
- 46. INFEEED FRAME
- 47. LOWER CURVE FRAME

# MODEL 661 BELT ASSEMBLY

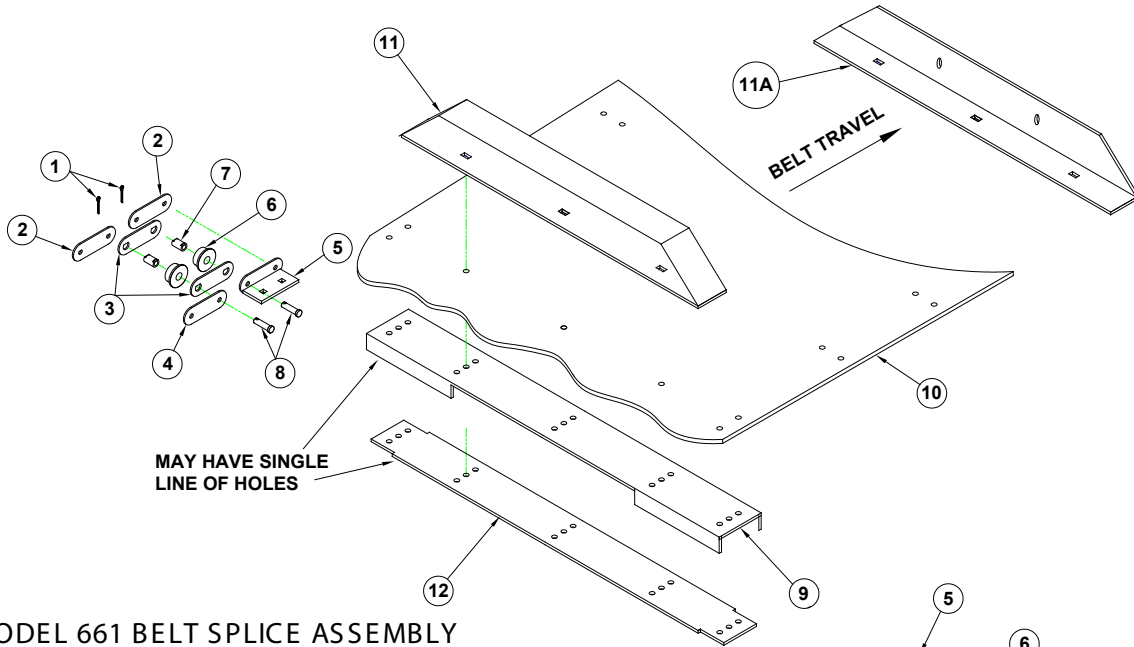

## MODEL 661 BELT SPLICE ASSEMBLY

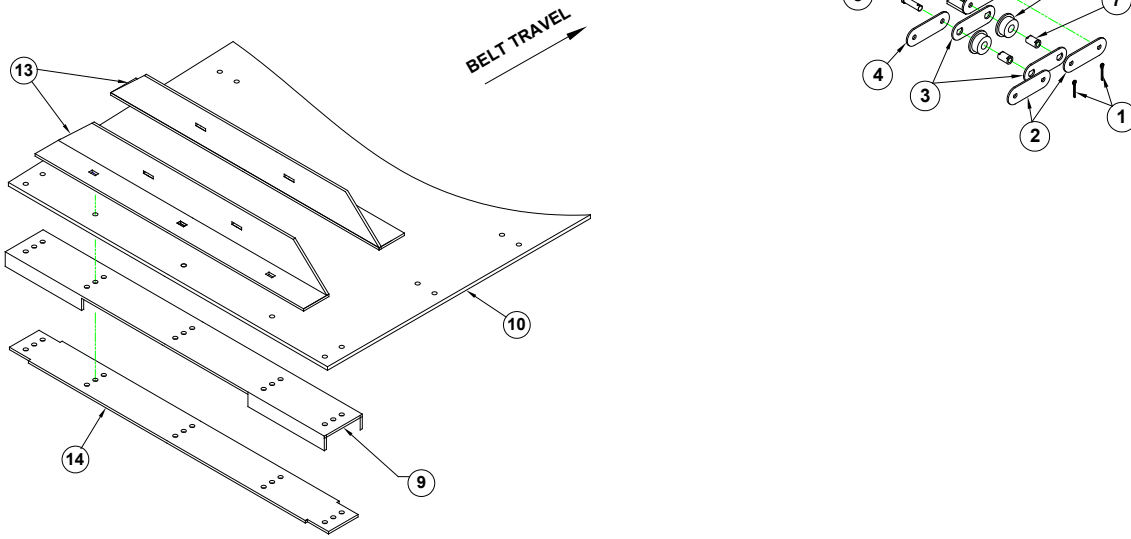

• Recommended spare parts to be stocked at your location

Part Number - Description	Qty.
---------------------------	------

- |      |                                    |  |
|------|------------------------------------|--|
| 1.   | • COTTER PIN                       |  |
| 2.   | • OUTSIDE SIDEBAR (SMALL-D HOLES)  |  |
| 3.   | • BUSHING SIDEBAR ( BIG-D HOLES)   |  |
| 4.   | • INSIDE SIDEBAR (ROUND HOLES)     |  |
| 5.   | • CLEAT ATTACHMENT PAD (WELDED)    |  |
| 6.   | • 3" DIA. FLANGED ROLLER           |  |
| 7.   | • BUSHING                          |  |
| 8.   | • CLEVIS PIN                       |  |
| 9.   | • CLEAT SUPPORT CHANNEL            |  |
| 10.  | • PVC BELT                         |  |
| 11.  | • BELT CLEAT (TUBE)                |  |
|      | OR                                 |  |
| 11A. | • ANGLE IRON BELT CLEAT            |  |
| 12.  | • CLEAT WEAR PAD (U.H.M.W.)        |  |
| 13.  | • SPLICE CLEAT                     |  |
| 14.  | • SPLICE CLEAT WEAR PAD (U.H.M.W.) |  |