

MODEL 670

DRAG CHAIN CONVEYOR

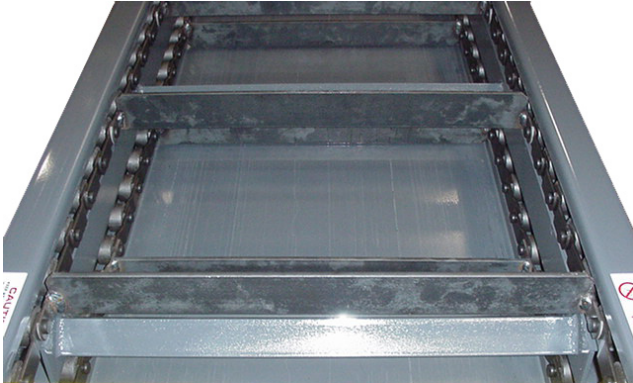

The **Model 670 Drag Flight Chain Conveyor** is ideal for handling cast iron, fine chips, scrap or sludge that would jam a Hinged Steel Belt unit. The 2-1/2" pitch chain has drag flights welded on 12-1/2" centers. Various configurations, lengths and belt widths are available.



MODEL 670 DRAG CHAIN STEEL BELT MODELS		
	Standard	Options
Belt Width	6", 8", 12", 18", 24", 30", 36"	Others Available
Belt Type	2-1/2" pitch chain	
Curves	30°, 45°, 60°	
Frame	8-5/8" deep formed 10 ga.	
Drive	1/2 H.P. 230/460/3/60	3/4, 1, 1-1/2, 2 HP 115/230/1/60, 575/3/60, TEFC, severe duty, inverter duty, brake motor
Drive Sprocket	5 Tooth, 4.25" P.D.	
Chain Pull	1,200 with No outside sidebars	2,500# with outside sidebars
Optional		
Drive location, H.P., fixed and variable speed, controls, tanks, chutes, plumbing, top covers, chip suppressors, casters, liquid tight bottom pans, paint, supports		
Many other options available, consult factory representative		

NOTE: Specifications subject to change without notice

MODEL 670 DRAG CHAIN CONVEYOR

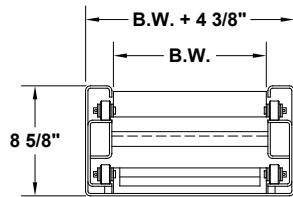

SECTION A-A

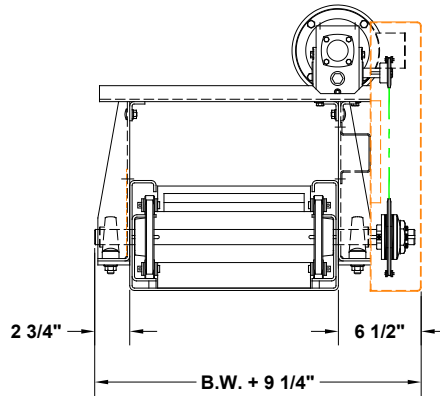

SECTION B-B

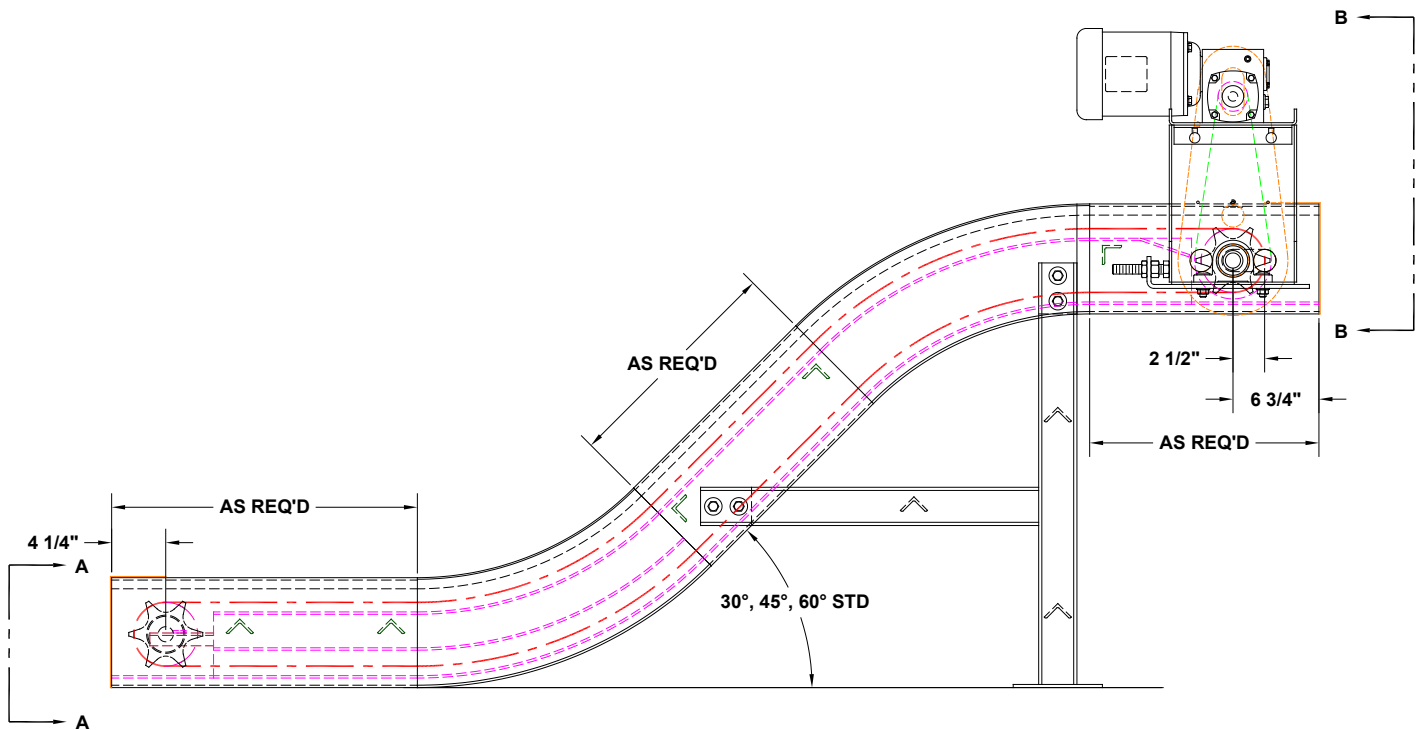

Bulletin 0616_670GH

735 Industrial Loop Road • New London, WI 54961-9612
 920-982-6600 • Fax 920-982-7750 • Toll Free 800-558-3616
 Website: www.titanconveyors.com • Email: sales@titanconveyors.com

