

# MODEL 460

## BULK HANDLING CONVEYOR



The **Model 460 Bulk Handling Conveyor** is specifically designed to handle large volumes of heavy, abrasive and granular products at a very reasonable cost. The Model 460's rugged construction and certified components provide for long runs and outdoor applications. Carrying 3 roll idlers are spaced on 4' centers in the intermediate section and spaced closer at each terminal. Infeed hoppers, skirting, belt scraper and supports are some of the available options.



MODEL 460 - 3 ROLL TROUGH BULK HANDLING	
	Standard
<b>Belt Widths</b>	Sized by application
<b>Lengths</b>	Per application
<b>Belt</b>	Per application
<b>Drive</b>	1 H.P. 230/460
<b>Drive Pulley</b>	14" dia. crown face rubber lagged drive and 14" tail
<b>Frame</b>	6" structural channel
<b>Idler Rollers</b>	2 or 3 roll CEMA
OPTIONS	
2-roll available, Drive as needed, Belt Width - consult factory, Idlers 35 & 45 degree available, consult factory on take-ups and maximum lengths, Drive location, Speed, Variable speed available, H.P., Controls, Infeed hoppers, skirting, belt scraper, Paint, Supports,	

**NOTE: Specifications subject to change without notice**

# MODEL 460

## BULK HANDLING CONVEYOR

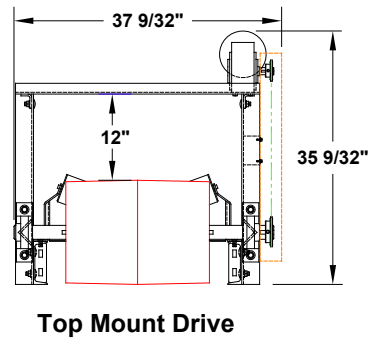
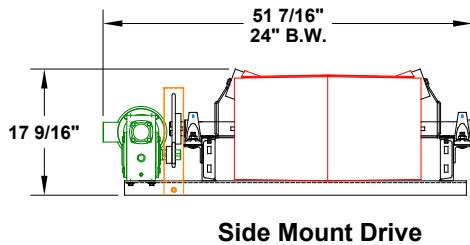
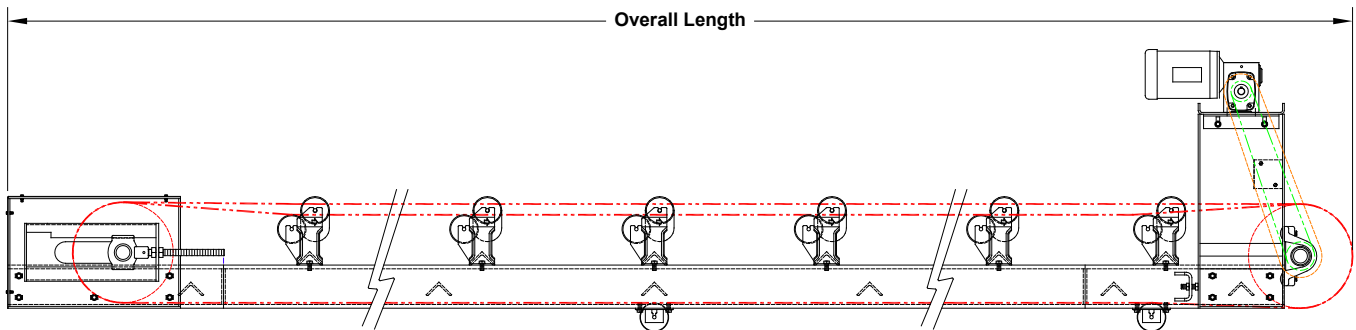
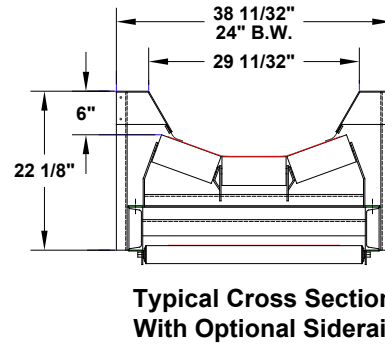
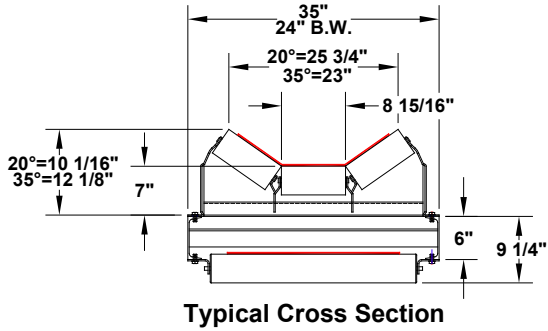

735 Industrial Loop Road • New London, WI 54961-9612  
 920-982-6600 • Fax 920-982-7750 • Toll Free 800-558-3616  
 Website: [www.titanconveyors.com](http://www.titanconveyors.com) • Email: [sales@titanconveyors.com](mailto:sales@titanconveyors.com)

