

MODEL 680

MULTI-STRAND CHAIN CONVEYOR

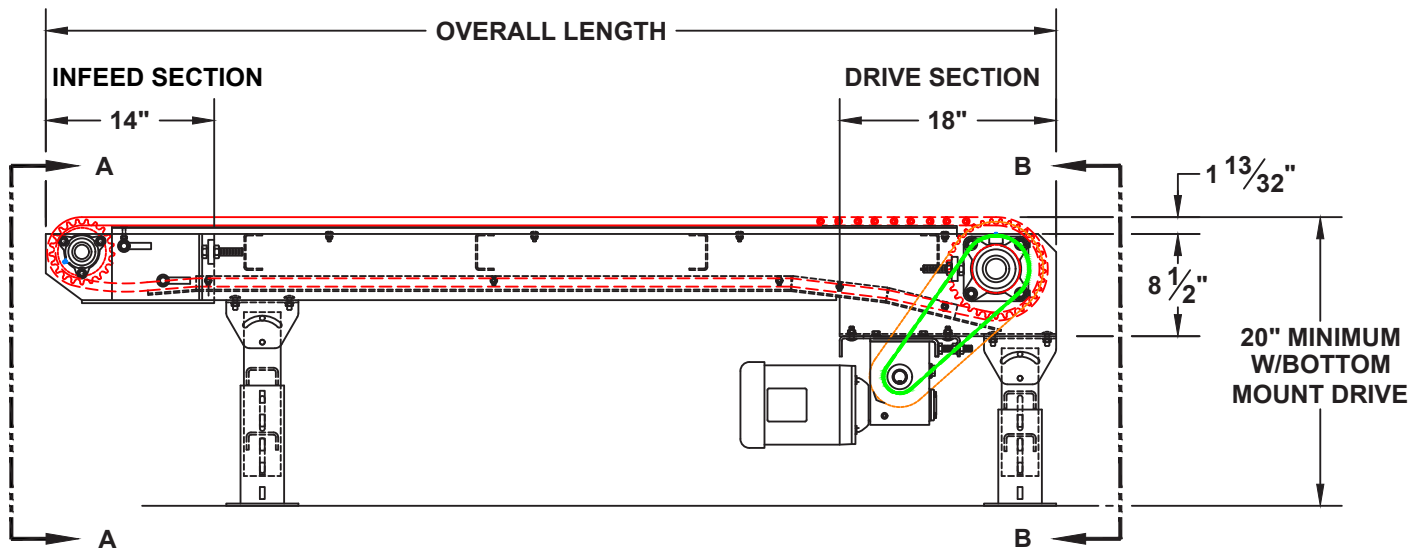
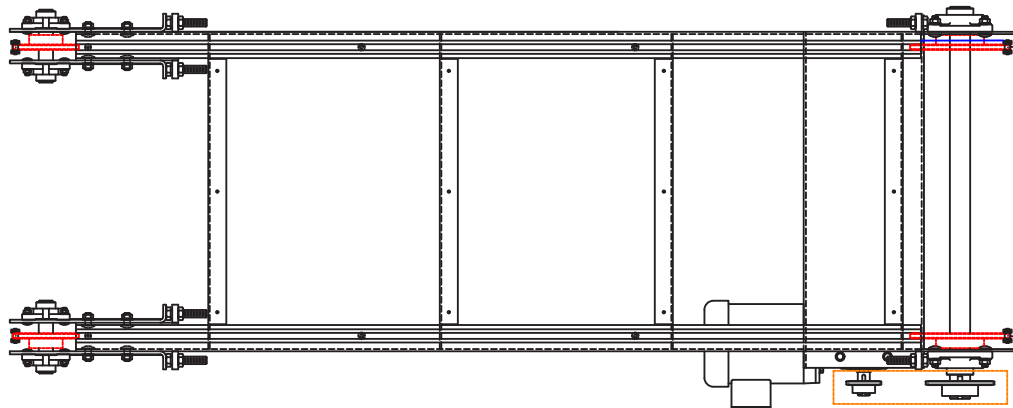
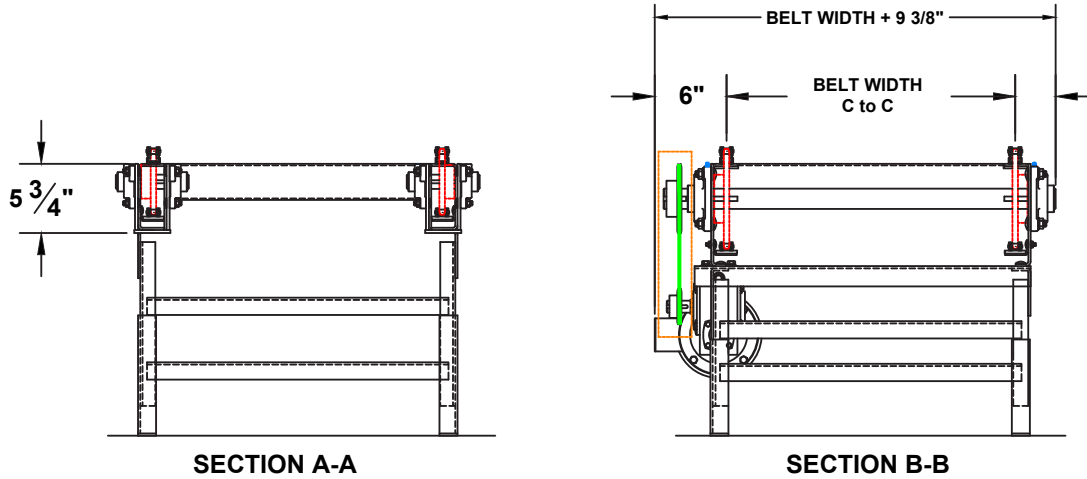

Bulletin 1018_680GH

735 Industrial Loop Road • New London, WI 54961-9612
 920-982-6600 • Fax 920-982-7750 • Toll Free 800-558-3616
 Website: www.titanconveyors.com • Email: sales@titanconveyors.com



MODEL 680

MULTI-STRAND CHAIN CONVEYOR

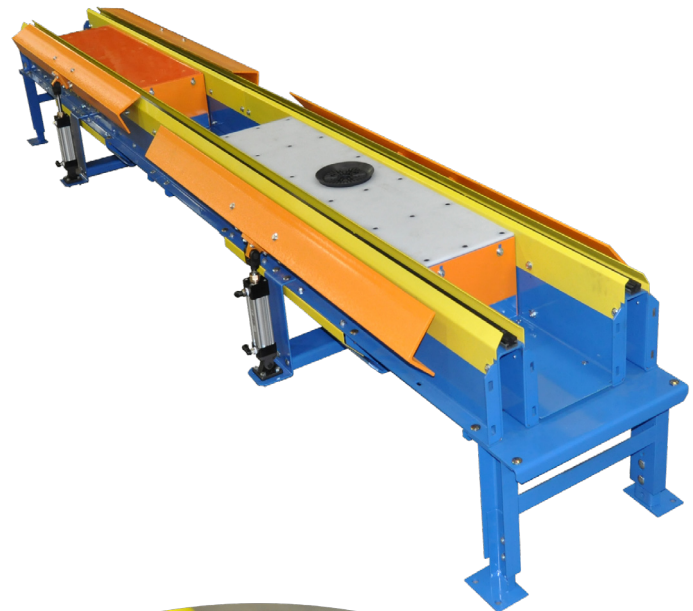

The **Model 680 Multi strand chain conveyor** is used to convey products that are not conveyable on a standard roller conveyor. The standard chain is C2060 double pitch with a load capacity of 2,400 lbs. Padded Chain is an option. An optional C2080 double pitch chain can be used for loads up to 4,000 lbs. Optional low profile side mounted drive and additional strands of chain can be added to increase load capacities.



Padded Chain

MODEL 680 MULTI-STRAND CHAIN CONVEYOR		
	Standard	Options
Chain	(2) strands of C2060	C2080, multiple strands available
Capacity	2,400 lbs	4,000 with (2) strands C2080
Drive	1 HP 230/460/3/60	Horsepower to fit application
Frame	Formed 7 ga.	Structural
Chain Speed	30 F.P.M.	Specify
Optional		
Drive location, HP, speed, variable speed available, controls, multiple chain strands, paint		

NOTE: Specifications subject to change without notice