



Replacement Parts RFQ for Model 519 & 525 - MDR Poly-O Belt Drive Motorized Roller Conveyor

Note: Chrome Browser will not email
- Download form and attach to an
email to: sales@titanconveyors.com

Company

Phone

Contact

Conveyor
Serial Number

E-mail

To Request a Quote for Spare Parts - Fill in the Information below & Quantity of each Part & Click on the Email Button

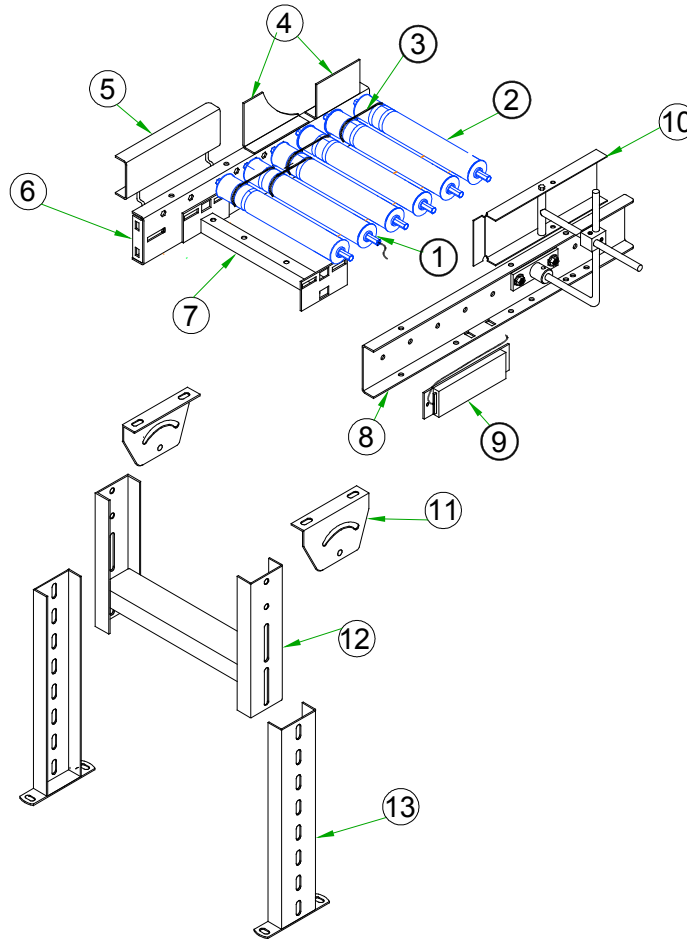

• Recommended spare parts to be stocked at your location

Part
Number - Description - Qty.

- 1. • MOTORIZED ROLLER
- 2. • DOUBLE GROOVE ROLLER
- 3. • O-BAND (URETHANE BELT)
- 9. • CONTROL MODULE

Other Parts

- 4. FIXED SIDE RAIL
- 5. HORIZONTAL ADJUSTABLE SIDE RAIL
- 6. BUTT COUPLING
- 7. CROSS MEMBER
- 8. INTERMEDIATE FRAME
- 10. ADJUSTABLE SIDE RAIL
- 11. SMILE BRACKET
- 12. UPPER SUPPORT
- 13. LOWER SUPPORT