



Industrial Conveyor Specialists

# MODEL 105 ROLLER BED CONVEYOR

When the application demands using rollers to decrease the friction factor, consider using the Titan **Model 105 Roller Bed Belt Conveyor**. The roller bed design allows you to carry heavier loads than a standard slider design. The Model 105 Roller Bed Belt Conveyor is offered with either a 4" or 8" diameter crown face rubber lagged drive pulley based on the load requirements. Model 105 Roller Bed Belt Conveyors use 4" diameter pulleys (lagged drive), 1.9" diameter x 16 gauge rollers with 7/16" hex axle. Standard roller centers are 6" but can be varied to suit your application. Model 105 Conveyors are designed to be compatible with other Titan Conveyors to allow you flexibility when designing your handling system.



MODEL 105 ROLLER BED BELT CONVEYORS		
	Standard	Options
<b>Belt Widths</b>	8" to 42"	4", 6"
<b>Lengths</b>	5' min. to 100' max.	3' min. to 150' max.
<b>Belt Type</b>	PVC #120 Black	Rough top, Food grade, to suit application
<b>Drive</b>	1/2 HP 230/460/3/60	3/4, 1, 1-1/2, 2, 3 HP, TEFC, washdown, severe duty, inverter duty, brake motor
<b>Drive Pulley</b>	4" dia. crowned rubber lagged	8" dia. becomes Model 109
<b>Frame</b>	5" deep formed 12 ga.	
<b>Roller Size</b>	1.9 dia. x 16 ga.	2.5 dia. x 11 ga.
<b>Rollers Center</b>	6" centers	Other centers available
<b>Optional</b>		
Belt widths from 4" to 48", lengths, roller spacing, roller size, other belt types; stainless construction, controls, e-stop with pull cord, transfer roller, rough top, food grade, H.P., center drive & take-up, drive location, speeds, variable speed drives, controls, siderails, supports, casters, special paint		

**NOTE: Specifications subject to change without notice**

# MODEL 105 ROLLER BED

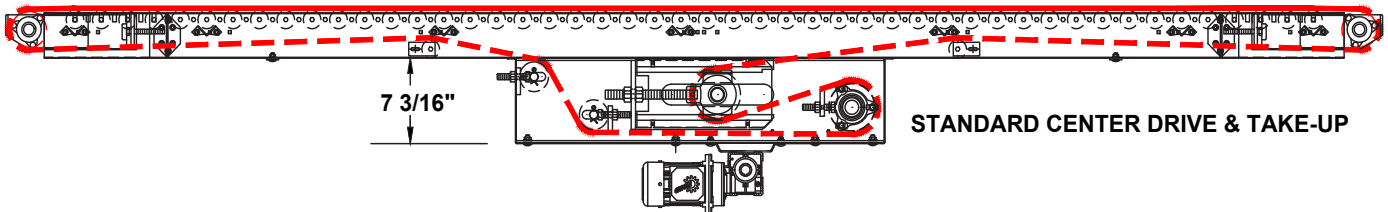
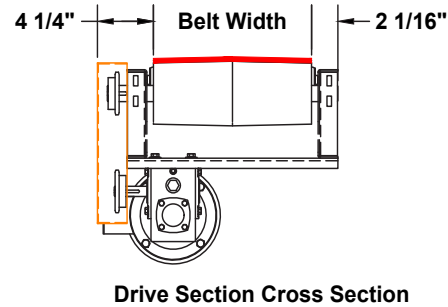
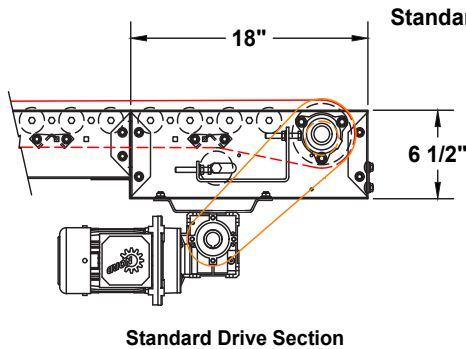
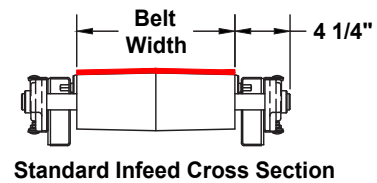
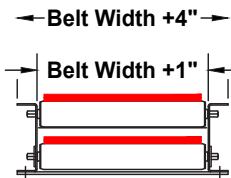
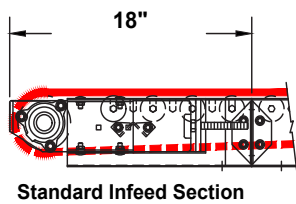
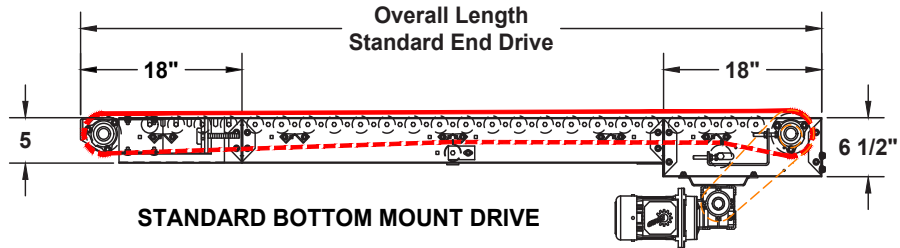

735 Industrial Loop Road • New London, WI 54961-9612  
 • 920-982-6600 • Fax 920-982-7750 • Toll Free 800-558-3616  
 Website: [www.titanconveyors.com](http://www.titanconveyors.com) • Email: [sales@titanconveyors.com](mailto:sales@titanconveyors.com)