

Model 304 Cleated Belt Conveyor

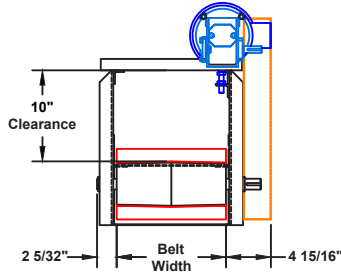

Optional Infeed Hopper

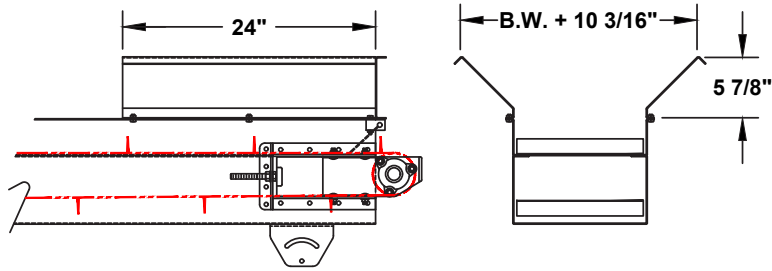

Section A-A

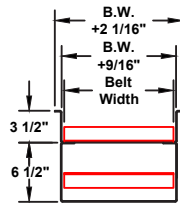

Section B-B

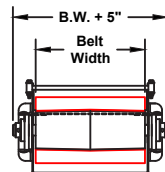

Section C-C

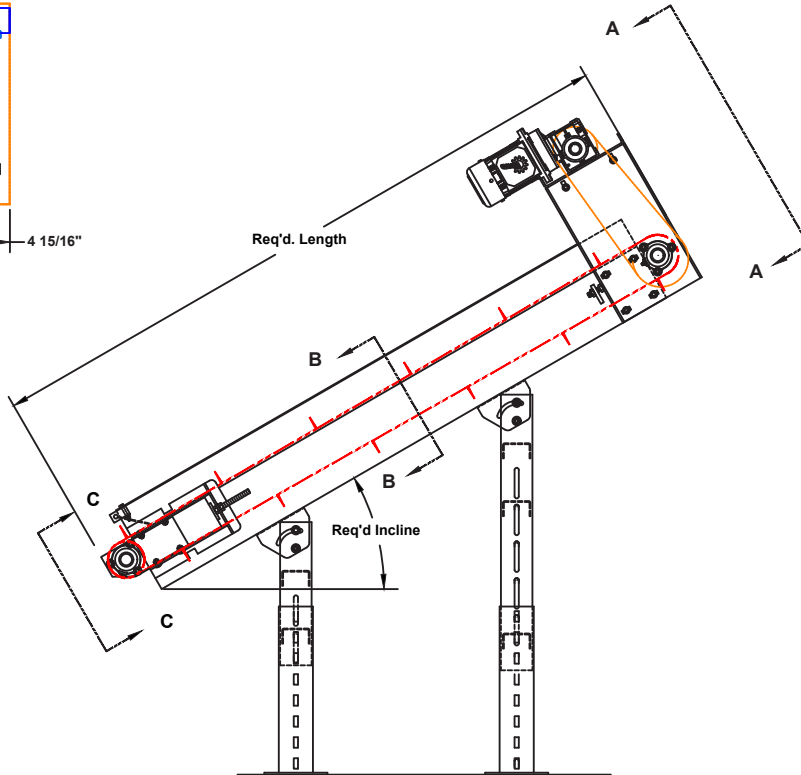

Optional Undercarriage Configuration Chart

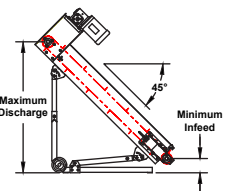
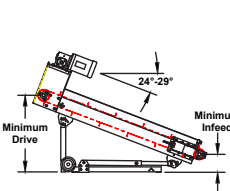
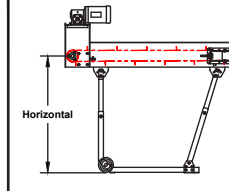
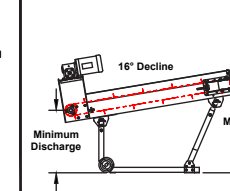
				
	Max. Dr. W/Min. In.	Max. Dr. W/Min. In.	Max. Dr. W/Min. In.	Max. Dr. W/Min. In.
4 Ft.	35 3/4" 5 1/4"	28" (29°) 7 1/4"	34 3/4" 35"	25 1/4" 36 3/4"
6 Ft.	52 1/2" 5 1/4"	39 1/4" (29°) 6 3/4"	46 3/4" 46 3/4"	31 1/2" 49 1/2"
8 Ft.	69 1/2" 5 1/4"	49 1/4" (28°) 6 1/2"	60 1/4" 60 1/4"	38" 63 3/4"
10 Ft.	86 1/2" 5 1/4"	56 1/2" (24°) 9"	77 1/4" 77 1/4"	- -
12 Ft.	103 1/2" 5 1/4"	66 1/4" (24°) 9"	77 1/4" 77 1/4"	- -



735 Industrial Loop Road • New London, WI 54961-9612
 920-982-6600 • Fax 920-982-7750 • Toll Free 800-558-3616
 Website: www.titanconveyors.com • Email: sales@titanconveyors.com