

MODEL Quench Conveyor

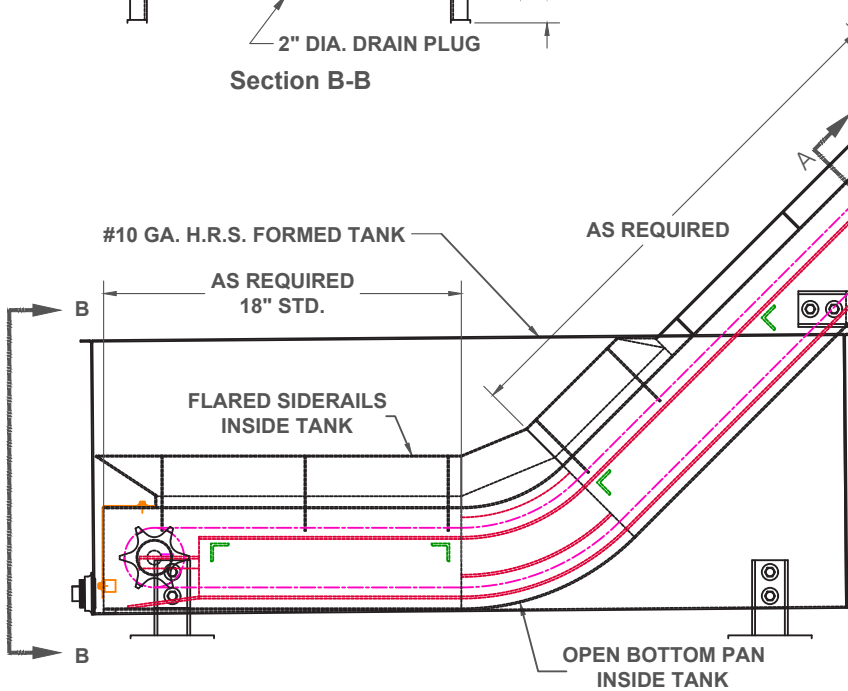

QUENCH CONVEYOR PROFILES AVAILABLE

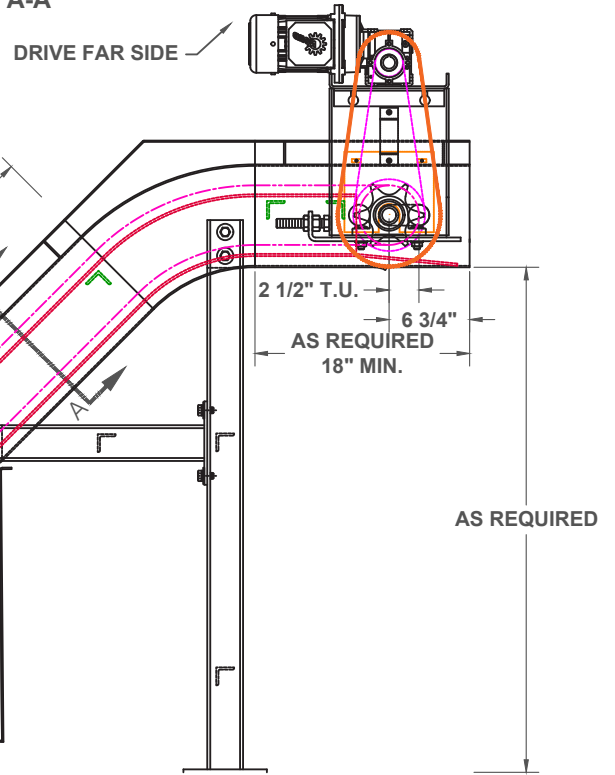
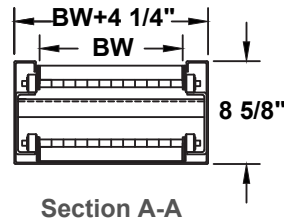
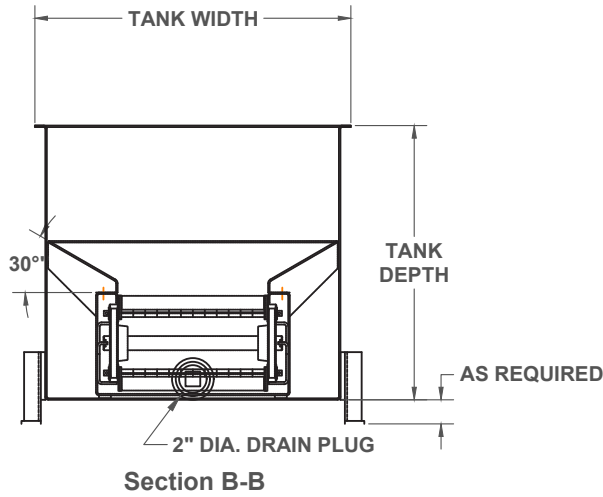
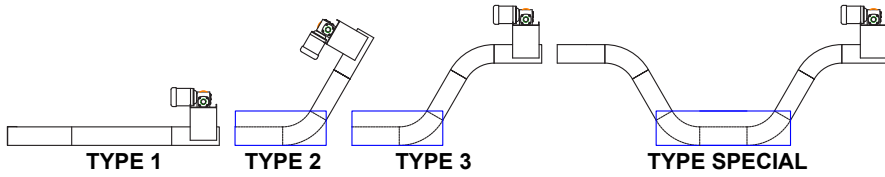

735 Industrial Loop Road • New London, WI 54961-9612
 920-982-6600 • Fax 920-982-7750 • Toll Free 800-558-3616
 Website: www.titanconveyors.com • Email: sales@titanconveyors.com